



ERGO LINE (GN 1/1)

Combo - Neutral - Heating Fan

- ✓ **Combine Two Boxes in One**
- ✓ **Superb Insulation Values**
- ✓ **Outstanding Manouverability**



ScanBox Ergo Line - Combo - Neutral - Heating - Fan is a range of products suited perfectly for any commercial kitchen operation requiring hot and cold holding or transport capacity. Designed with two fully seperated box compartments stacked on eachother. Intuitive controls, ergonomic design and a wide range of different sizes and accessories will gurantee a perfect match with your operation. Designed with ScanBox latest Environmental Performance (ExP) technology combining increased performance with a decreased environmental impact. Designed to fit equally well back of house as well as front of house allowing exterior branding options.

Function

Two boxes in a stacked combination. One well insulated Neutral box and one fan heated system that provides exact and even heat distribution. Adjustable temperature setting and moisture ventilation gets you in control of food quality. Heat up time approximately 25 minutes. Neutral box can be equipped with cooling plates to prolong temperature retention.

| Standard Equipment | Options |
|--------------------------------|---------------------|
| Backmounted Heating S/S Heater | International Plugs |
| Adjustable Temperature | |
| Adjustable Moisture Vent | |
| European Plug Type | |

Capacity

Equipped with detachable stainless steel racks allowing the air to circulate freely inside the cavity. The u-shaped racks has a tilt-stop function securing the foodcontainer and lid during loading, unloading and transport. Variety of sizes and rack configurations allowing optimal usage of the box.

| Standard Equipment | Options |
|-----------------------|-------------------------|
| GN 1/1 80 mm distance | Optional level distance |
| Detachable Racks | |
| Tilt-Stop Function | |

Mobility

Lightweight, yet heavy duty. A solid design made for all types transports including truck. Equipped with non-marking, high quality double bearing castors for easy manouverability even in cramped spaces. Precision moulded PPE insulation assures food temperature and safety when the box is not plugged into power.

| Standard Equipment | Options |
|------------------------|-------------------------|
| Ø160 mm Castors | Optional Sized Castors |
| Double Bearing Castors | Stainless Steel Castors |
| Transport Handles *4 | XC Castors |
| | Tow Bars |

Ease of Use

Equipped with an intuitive and easy to use display conviniently positioned in front top of unit. All-around top frame allows easy handling facing the unit from any direction. The 4,5 meter long single phase spiral cord is positionned on the back of the unit.

| Standard Equipment | Options |
|-----------------------------|-------------------------|
| Excenter lock | Sight window/Glass door |
| Extra Long Spiral Cord | One Grip Handle Tray |
| Digital Controller in Front | holder foldable |
| Central brake system | |

Construction

A heavy duty yet lightweight construction based on a stainless steel framing, reinforced plastic exterior panels, solid high precision moulded polyrethane foam insulation and anonized aluminium interior. A smooth, hygienic and fully sealed inner cavity without welds or rivets. The frame, top hood and handles are in robust stainless steel.

| Standard Equipment | Options |
|------------------------|---------|
| Smooth Hygienic Cavity | |
| Smooth S/S Top | |
| S/S Framing | |

Exterior Design

Robust and elegant Scandinavian design made for both back of house as well as front of house operations. Possibility to choose different colours as well as adapting parts or the full box according to corporate branding. Use the design and let the box be a part of the full F&B experience.

| Standard Equipment | Options |
|---------------------|-------------------|
| Black Glossy Finish | Optional colors |
| Black (RAL 9005) | Signature concept |

Product Safety

High quality product Made in Sweden with high level of engineering details to performance, safety and easy of use. Thorough quality and safety testing through external third party. CE marked with complimentary EMC, RoHS, REACH and electrical safety testing.





Technical Specification

Model Series



ERGO LINE - Combo - Neutral - Heating Fan

| Product Models | NE04 + HF04 | NE04 + HF06 | NE04 + HF08 | NE06 + HF06 |
|---|-----------------------|-----------------------|-----------------------|-----------------------|
| Article Number | ELCNF44 | ELCNF46 | ELCNF48 | ELCNF66 |
| Active Heating | | | | |
| Controller | Digital adjustable | Digital adjustable | Digital adjustable | Digital adjustable |
| Heat Source | Electric Element | Electric Element | Electric Element | Electric Element |
| Temperature Range | Ambient up to 90°C | Ambient up to 90°C | Ambient up to 90°C | Ambient up to 90°C |
| Heating Time *1 | 20 min | 30 min | 20 min | 30 min |
| Energy consumption to operating temp *2 | 0,15 kWh | 0,20 kWh | 0,25 kWh | 0,20 kWh |
| Capacity | | | | |
| Standard | GN 1/1 | GN 1/1 | GN 1/1 | GN 1/1 |
| Pitch between levels | 80 mm | 80 mm | 80 mm | 80 mm |
| Number of 65 mm containers | 4 + 4 | 4 + 6 | 4 + 8 | 6 + 6 |
| Number of 100 mm containers | 2 + 2 | 2 + 4 | 2 + 5 | 4 + 4 |
| Number of 150 mm containers | 1 + 1 | 1 + 2 | 2 + 3 | 3 + 3 |
| Maximum load per rack | 9 kg | 9 kg | 9 kg | 9 kg |
| Maximum load in unit | 36 + 36 kg | 36 + 54 kg | 36 + 72 kg | 54 + 54 kg |
| Max total weight (full unit) | 125 kg | 145 kg | 165 kg | 165 kg |
| Physical Attributes | | | | |
| External dimensions (W x H x D) mm | 540 x 1277 x 810 | 540 x 1437 x 810 | 540 x 1597 x 810 | 540 x 1597 x 810 |
| Internal dimensions (W x H x D) mm | 352 x 412 / 412 x 600 | 352 x 412 / 572 x 600 | 352 x 412 / 732 x 600 | 352 x 572 / 572 x 600 |
| Volume | 87 + 87 Liter | 87 + 121 Liter | 87 + 154 Liter | 121 + 121 Liter |
| Net weight (empty unit) | 52 kg | 56 kg | 60 kg | 60 kg |
| Door opening | 270° | 270° | 270° | 270° |
| Length of Powercable | 4,5 m | 4,5 m | 4,5 m | 4,5 m |
| Electrical Attributes | | | | |
| Rated Voltage | 220-240V / 1 phase | 220-240V / 1 phase | 220-240V / 1 phase | 220-240V / 1 phase |
| Rated Frequency | 50-60 Hz | 50-60 Hz | 50-60 Hz | 50-60 Hz |
| Rated Current | 1,82 A | 1,82 A | 3,19 A | 1,82 A |
| Power rating | 385 W | 385 W | 700 W | 385 W |
| IP Code *3 | 44 | 44 | 44 | 44 |

Dimension drawings

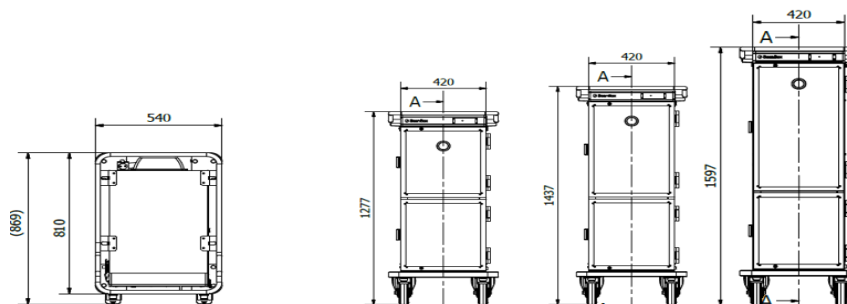

*1 - Time for a hot unit to reach 80 ° C and for a cold unit to reach 5 ° C average temperature in the air in the cavity with 22 ° C ambient temperature.

*2 - Operating temperature in hot unit of 80 ° C and in cold unit of 5 ° C with 22 ° C ambient temperature.

*3 - IP44 = Protection against penetration of solid objects larger than 1 mm and protected against splashing water from all angles (IEC 60529)

*4 - Vertical Push / pull handles standard on ELCNF48 + ELCNF66